

[CONTRIBUTION FROM THE DEPARTMENT OF CHEMISTRY AND THE PURDUE RESEARCH FOUNDATION, PURDUE UNIVERSITY]

The Molecular Structure of Methyl Cyanide and Trifluoromethyl Cyanide by Electron Diffraction¹

BY M. D. DANFORD AND R. L. LIVINGSTON

RECEIVED JANUARY 11, 1955

The molecular structures of methyl cyanide and trifluoromethyl cyanide have been investigated by electron diffraction using the visual correlation procedure. For methyl cyanide the structural parameters C-C = 1.46₅ Å., and C-N = 1.15₅ Å. were obtained, with C-H and ∠HCH assumed to be 1.10 Å. and 109.5°, respectively; these results differ from those of previous electron diffraction investigations but are in excellent agreement with a recent microwave determination. The parameters for trifluoromethyl cyanide were determined by electron diffraction as C-F = 1.33 Å., C-N = 1.15 Å., C-C = 1.50₅ Å., and ∠FCF = 108.5°. A combination of these values of C-F and ∠FCF with results from microwave spectroscopy yields a C-C distance of 1.475 Å. if one assumes a C-N distance of 1.16 Å.

Introduction

This investigation was originally undertaken to determine further the effect of attached groups on the carbon-fluorine distance in compounds of the type F₃CX. In addition, the C-C and C-N distances are of interest in connection with a study of the effects of fluorine atoms on bond distances.

Conflicting results on the structure of methyl cyanide suggested a redetermination of its structure to provide a reliable comparison with trifluoromethyl cyanide. An early electron diffraction study² of methyl cyanide gave C-C = 1.54 ± 0.02 Å., while a later investigation³ by electron diffraction C-C = 1.49 ± 0.03 Å. and C-N = 1.16 ± 0.03 Å.; both of these results are in disagreement with a more recent microwave determination⁴ which yielded C-C = 1.460 Å. and C-N = 1.158 Å.

Shortly after this investigation was undertaken, a microwave study⁵ of trifluoromethyl cyanide provided additional structural information and the most accurate results for this compound are those which combine these microwave results with the results of the present diffraction study.

Experimental

Methyl cyanide was obtained by distillation of a commercial sample. Infrared spectra and refractive indices of various fractions were taken at intervals, and after these failed to show further change, a sample boiling at 81.7° (uncorrected) was used for preparation of the diffraction photographs.

Trifluoromethyl cyanide was prepared by the method described by Gilman and Jones⁶ and purified by distillation through a low temperature Hyd-Robot Podbielniak column, with the fraction boiling at -66°, one atmosphere pressure, being collected for this investigation.

A series of photographs was obtained for each compound using the method described by Brockway.⁷ Exposures of methyl cyanide were made on Kodak 33 plates using a camera distance of 108.07 mm., and four plates, with electron wave lengths (as determined from transmission patterns of zinc oxide) of 0.06438, 0.05997, 0.06026 and 0.05613 Å. were selected for quantitative interpretation. Exposures of trifluoromethyl cyanide were made on Kodak Super Ortho-Press plates, and three plates with electron wave lengths of 0.05594, 0.06001 and 0.06389 Å. were used for quantitative

interpretation. The experimental curve for methyl cyanide is based on intensity estimates and about thirty measurements of each feature by three independent observers, and that for trifluoromethyl cyanide is based on intensity estimates and about twenty-five measurements of each feature, also by three independent observers.

Correlation Procedure.—The visual correlation procedure was employed for both compounds, with theoretical curves being calculated by the equation

$$I(q) = \sum_i \sum_j \frac{Z_i Z_j}{r_{ij}} \exp(-b_{ij} q^2) \sin \frac{\pi q r_{ij}}{10} \quad (1)$$

using the punched card method.⁸ Radial distribution curves^{8,9} were calculated using the function

$$rD(r) = \sum_{q=1}^{q_{\max}} I(\text{obs}) \exp(-bq^2) \sin \frac{\pi q r_{ij}}{10} \quad (2)$$

where $\exp(-bq^2) = 0.1$ for $q = q_{\max}$.

Methyl Cyanide.—The values of b_{ij} used in equation 1 are summarized in Table I, and the averages of the q_0 values for each feature are shown in Table II.

TABLE I

VALUES OF b_{ij} USED FOR METHYL CYANIDE MODELS

Distance	$b_{ij} \times 10^3$	Distance	$b_{ij} \times 10^3$
C-H	16.0	C-N	0
C-H	30.0	C-N	0
H-H	∞	H-N	55.0
C-C	1.0		

The visual curve shown in Fig. 1 was drawn with the aid of reference patterns. Maxima 3 and 5 are similar to the type of feature obtained for CO₂, while maximum 4 is broader, with less distinct shoulder, and for this reason was not used in determining the scale factor. Minimum 6 was also omitted because of a large discrepancy between measurements by different observers. Maximum 1 and minimum 2 were omitted because of the uncertainty of measurement of the inner features.

All models were calculated assuming the symmetry of the point group C_{3v}, with the ∠HCH and C-H distances being kept at 109.5° and 1.10 Å., respectively. The C-C and C-N distances were varied as shown by the parameter chart in Fig. 2, where the dotted line encloses the range of acceptable models. These limits for acceptable models were established as follows.

(8) P. A. Shaffer, Jr., V. Schomaker and L. Pauling, *J. Chem. Phys.*, **14**, 659 (1946).

(9) L. Pauling and L. O. Brockway, *This Journal*, **67**, 2684 (1935).

(1) Contains material from the Ph.D. thesis of M. D. Danford, Purdue Research Foundation Fellow in Chemistry, 1953-1954.

(2) L. O. Brockway, *This Journal*, **58**, 2516 (1936).

(3) L. Pauling, H. D. Springall and K. J. Palmer, *ibid.*, **61**, 927 (1939).

(4) M. Kessler, H. Ring, R. Trambarulo and W. Gordy, *Phys. Rev.*, **72**, 1262 (1947).

(5) J. Sheridan and W. Gordy, *J. Chem. Phys.*, **20**, 591 (1952).

(6) H. Gilman and R. G. Jones, *This Journal*, **65**, 1458 (1943).

(7) L. O. Brockway, *Revs. Mod. Phys.*, **8**, 231 (1936).

TABLE II
QUANTITATIVE ELECTRON DIFFRACTION DATA FOR CH₃CN

Max.	Min.	$q_{obs.}$	B_2 q/q_0	B_3 q/q_0	C_2 q/q_0	C_3 q/q_0	D_2 q/q_0	D_3 q/q_0
1		20.48	(0.958)	(0.943)	(0.943)	(0.937)	(0.911)	(0.923)
	2	28.89	(1.000)	(.995)	(.974)	(.964)	(.945)	(.938)
2		32.61	1.006	.983	.976	.956	.950	.931
	3	36.30	0.986	.971	.963	.949	.945	.925
3		40.19	1.009	1.002	.983	.977	.959	.951
	4	51.58	0.982	0.970	.958	.942	.931	.919
4		55.63	(1.030)	(1.015)	(.998)	(.985)	(.965)	(.956)
	5	66.25	1.001	0.987	.973	.959	.944	.930
5		70.56	1.026	1.011	.995	.978	.964	.949
	6	81.01	(1.012)	(1.004)	(.981)	(.970)	(.950)	(.940)
6		85.16	1.029	1.006	.998	.978	.968	.950
	Av.		1.006	0.990	0.978	0.963	0.952	0.936
	Av. dev.		±0.0136	±0.014	±0.012	±0.0116	±0.0104	±0.0115

Curves for models designated with subscript 1 all have the shoulder on maximum 3 too well resolved, as shown by curve C₁ in Fig. 1. Those with subscript 4 show maximum 5 as a doublet as illustrated by curve C₄. Models A₂ and A₃ were rejected because of the absence of a fairly prominent shoulder on maximum 4 as is seen by curve A₂. Curve E₂ was rejected for the same reason as E₁ while E₃, shown in Fig. 2 has the wrong shape for the first maximum.

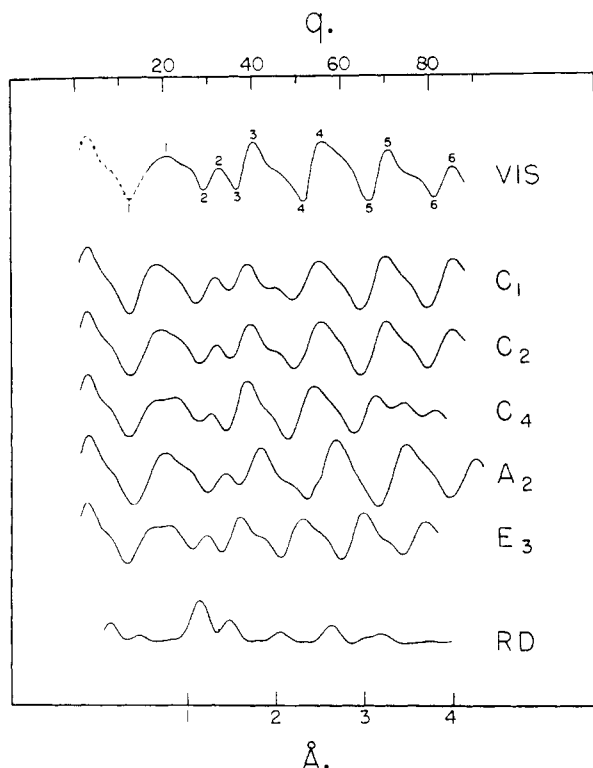

Fig. 1.—Visual intensity, theoretical intensity and radial distribution curves for methyl cyanide.

Of the models enclosed by the dotted lines in Fig. 2, the B and D models are less satisfactory than the C models; the final structure is thus chosen as one in between models C₂ and C₃. The mean q/q_0 values for all acceptable models are

shown in Table II, and final results are listed in Table III.

TABLE III
INTERATOMIC DISTANCES IN CH₃CN
RD: radial distribution curve.

Model	C-C	C-N	C-N
B ₂	1.459	1.157	2.616
B ₃	1.475	1.139	2.614
C ₂	1.457	1.164	2.621
C ₃	1.473	1.146	2.619
D ₂	1.457	1.171	2.628
D ₃	1.470	1.151	2.621
RD	1.47	(1.16)	2.63

Results of this investigation

C-C distance 1.465 ± 0.02 Å.
C-N distance 1.155 ± 0.03 Å.
C-N distance 2.62 ± 0.03 Å.

The radial distribution curve (Fig. 1), calculated by equation 2, gave peaks at r values of 1.13, 1.47, 2.04, 2.63 and 3.18 Å. Resolution of the C-H and C-N distances was not possible, and the peak at 1.13 Å. represents the combined effect of these dis-

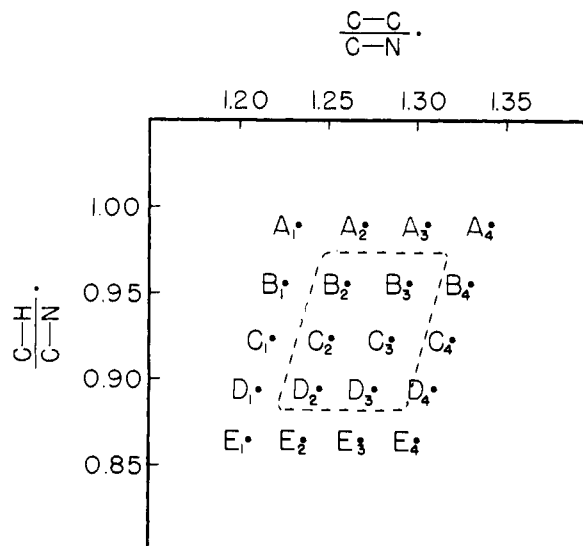

Fig. 2.—Parameter chart for methyl cyanide indicating models for which theoretical curves were calculated.

tances. Major distances are represented by the peaks at 1.47 Å. (C-C distance), and 2.63 (C...N distance). A combination of these distances gives a C-N distance of 1.16 Å., in good agreement with results of the visual correlation procedure. The peaks at 2.04 and 3.18 Å. represent the C-H and N...H distances, respectively.

Trifluoromethyl Cyanide.—The visual curve for CF_3CN is shown in Fig. 4. Maxima two and three were given double weight, and minima two and four were omitted in the determination of q/q_0 values. The averages of q_0 values for each feature are listed in Table V, and values of b_{ij} used in equation 1 are summarized in Table IV.

TABLE IV

VALUES OF b_{ij} USED IN TRIFLUOROMETHYL CYANIDE MODELS

Distance	$b_{ij} \times 10^4$	Distance	$b_{ij} \times 10^4$
C-F	1.5	C...N	4.6
C...F	9.0	N...F	25.5
F...F	6.89	C-N	0
C-C	1.0		

Models were calculated assuming C_{3v} symmetry, with the C-F distance fixed at 1.33 Å., and the $\angle\text{FCF}$ and C-C distance being varied in planes with fixed C-N distances, as shown by the parameter chart in Fig. 3, which was surveyed in planes with C-N = 1.07, 1.10, 1.13, 1.16, 1.19 and 1.22 Å.

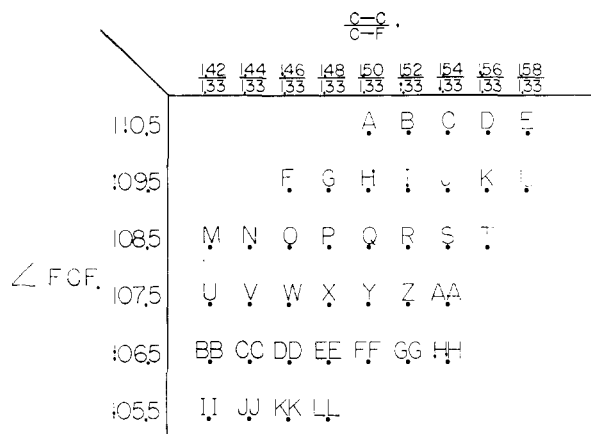

Fig. 3.—Parameter chart indicating models of trifluoromethyl cyanide for which theoretical intensity curves were calculated.

Very liberal criteria were used in establishing the limits of acceptability of models due to the difficulty in interpretation of the shapes of certain features ($q = 58$ to $q = 70$ and $q = 80$ to $q = 90$). Representative curves for all models are shown in Fig. 4, with subscripts 2, 3 and 4 designating C-N values of 1.13, 1.16 and 1.19 Å., respectively. All models were accepted, rejected or designated as borderline fits on the basis of the criteria discussed below.

Curve Q_3 represents the most acceptable model. Curves X_2 through Y_2 illustrate the shapes which were accepted for the triplet feature. Maximum 7 in curve X_2 is less intense than maximum 6, but was accepted. The shapes of the features comprising the triplet in curves I_4 through Y_2 are markedly different from those in curve Q_3 , but all of

these curves were accepted as borderline fits. Minima 7 and 9 do not seem sufficiently deep in curve I_4 , while maximum 5 in curve S_2 is almost too weak to be acceptable. Minimum 7 is not distinct in curve I_2 and maximum 5 in curve Y_2 is very weak.

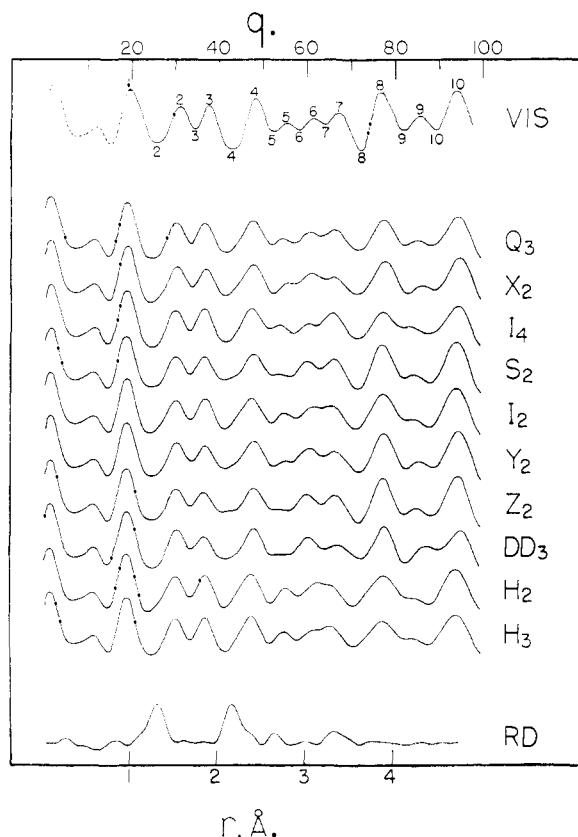

Fig. 4.—Visual intensity, theoretical intensity, and radial distribution curves for trifluoromethyl cyanide.

Curve Z_2 was rejected on the basis of the shoulder on the inside of maximum 4, in addition to the appearance of a flat shelf in place of maximum 5. In curve DD_3 , a flat shelf again appears in place of maximum 5 in addition to the unacceptable appearance in the region of maxima 9 and 10. Curve H_2 was rejected because maxima 7 and 9 are too weak, while curve H_3 was rejected because of the weakness of maximum 6.

The average deviation for all acceptable models ranged between 0.005 and 0.009 and because of the large number of acceptable models, the q/q_0 values for curve Q_3 only are shown in Table V. Final results are listed in Table VI.

In the radial distribution curve (Fig. 4) peaks were obtained at r values of 1.32, 2.17, 2.66 and 3.35 Å. The first of these represents the combined effect of the C-N, C-F and C-C distances, while the peak at 2.17 Å. is a result of the combined effect of the F-F and C-F distances. Peaks at 2.66 and 3.35 Å. represent the C-N and F-N distances, respectively.

Discussion of Results

Results obtained for methyl cyanide are in excellent agreement with the microwave determina-

TABLE V
QUANTITATIVE DATA FOR CF_3CN

Max.	Min.	$q_{\text{obs.}}$	q/q_0 (model Q_1)
1		19.72	0.992
	2	25.62	(0.988)
2		30.86	0.998
	3	34.35	0.997
3		37.34	1.003
	4	43.03	(0.979)
4		48.15	1.006
	5	52.39	1.003
5		55.41	0.999
	6	58.53	0.984
6		61.49	0.999
	7	64.23	0.992
7		67.14	0.995
	8	72.20	1.000
8		76.74	1.014
	9	81.77	1.011
9		85.57	0.999
	10	89.70	0.988
10		94.12	1.006
		Av.	0.999
		Av. dev.	± 0.005

TABLE VI
INTERATOMIC DISTANCES IN TRIFLUOROMETHYL CYANIDE
(IN Å.)

Distance	Extreme values (all acceptable models)	Av. values (all acceptable models)	Final values	Radial distribution results
C-F	1.320-1.339	1.328	1.33 ± 0.02	1.32
C-C	1.461-1.552	1.507	$1.505 \pm .06$..
C-N	1.097-1.188	1.147	$1.15 \pm .06$..
C...F	2.305-2.354	2.331	$2.33 \pm .04$..
C...N	2.628-2.691	2.655	$2.66 \pm .05$	2.66
F...F	2.147-2.174	2.158	$2.16 \pm .03$	2.17
F...N	3.340-3.386	3.356	$3.36 \pm .04$	3.35

tion (see Introduction), but do not agree with previous electron diffraction results. No vibration factors were used in the previous electron diffraction studies; in addition, only one theoretical curve apparently was calculated in the investigation by Brockway,² while only three were calculated by Pauling, Springall and Palmer.³ The experimental

curve in the study by Brockway extended to about $s = 22$, and that by Pauling, Springall and Palmer to about $s = 25$, while that for the present investigation extends to $s = 27$.

Some further comparisons between the results of this investigation and those obtained by Pauling, Springall and Palmer seem to be in order. The visual curve for CH_3CN obtained in this study is in good agreement with the most acceptable theoretical curve of the earlier study with the exception of maxima 4 and 5. The present authors have interpreted maximum 4 as being asymmetric with a broad, rounded shoulder on the outside; in the previous investigation, no asymmetry was apparently observed in this peak. The shoulder on maximum 5 was interpreted in the earlier study as a distinct maximum rather than as indicated by the visual curve shown in Fig. 2. In addition, the q_0 values of the previous study are lower than those reported here in every case except one. Finally, the radial distribution curve of the earlier study gave peaks at 1.17, 1.53, 2.16, 2.63 and 3.25 Å., which are significantly different from the values reported here.

In the microwave investigation of CF_3CN , one moment of inertia was obtained for each of the isotopic molecules, $\text{CF}_3\text{CN}^{14}$ and $\text{CF}_3\text{CN}^{15}$. Assuming $\angle\text{FCF} = 108^\circ 28'$ and $\text{C-N} = 1.158$ Å., these moments lead to $\text{C-C} = 1.472$ Å. and $\text{C-F} = 1.333$ Å. Since the parameters C-F and $\angle\text{FCF}$ are determined by electron diffraction more accurately than the C-C and C-N distances, it seems reasonable to combine the diffraction values of the former parameters with the microwave data. A unique solution is still not possible, but models with C-N between 1.150 and 1.160 Å. give a C-C distance between 1.474 and 1.480 Å. It appears that the electron diffraction value for the C-C distance is not in very close agreement with the microwave results. Thus, within the limits of experimental error, there is no detectable difference between the C-C distances in CH_3CN and CF_3CN . Values for the C-F distance (1.33 ± 0.02 Å.), and the $\angle\text{FCF}$ ($108.5^\circ \pm 1.5^\circ$), are in excellent agreement with those obtained for other molecules of the type F_3CX , and with the microwave results.

LAFAYETTE, INDIANA